

Manual for the Gas Sampling Probe:

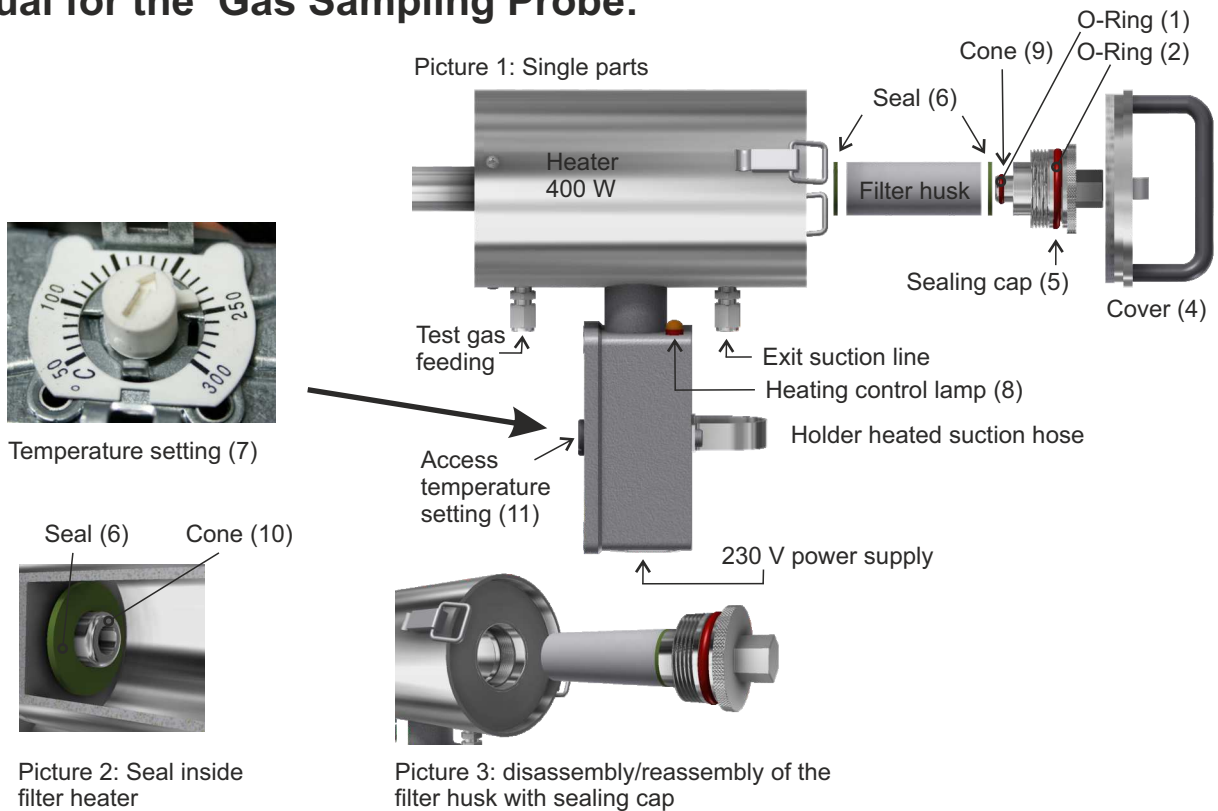

Heater 400 W: The probe is equipped with a high performance coil heater, which heats the exhaust pipe and the rear segment of the filter. The default value for the temperature of the filter is 200 °C. By opening the access (11) can be set a new temperature with the knob (7) (setting filter: desired temperature + 50). More than 250 °C should not be set.

If the power is connected, the heating process starts. The small LED (8) indicates the heating phase. The temperature is reached when the light goes out. If the temperature is below the desired temperature, the heater is switched on again and the lamp illuminates.

Test gas feeding: For calibration can here gas feeding in front of the filter. The test gas flow in front of the filter and will be mixed with the sucked gas.

ATTENTION:
If no test gas is connected, the port must be closed! Use closing caps!

Exit suction: Here is the exit from the sucked gas behind filter to connect it with a heated flexible hose to the analyser.

Filter husk: To replace the filter husk, the rear cover (4) must be removed. The filter husk is sealed gas-tight through the sealing cap (5) with the seals (6) against the suction pipe. To remove the filter husk must be unscrewed the sealing cap (5) with the accompanying wrench (19 mm).

The dust loading-gas first flows through the filter husk, so that a complicated cleaning of the internal parts from the filter heater is not necessary.

Insert a new filter husk:

Fit the new filter husk on the guide cone (9) over the O-ring (1) on the sealing plug. A gasket (6) must be placed between the filter husk and the sealing cap (5) and on the guide cone (10) inside the filter heater (Figure 2).

The O-ring (2) need not be removed and is only for the sealing of the sealing cap (5).

The sealing cup (5) is screwed with the mounted filter husk in the heater (Figure 3).

The screwing is only possible when the filter husk is pushed over the guide cone (10) inside the heater.

The sealing cap (5) should be closed and tightening with the socket wrench.

The gaskets (6) provide for a gas-tight connection.

Paul Gothe GmbH
Wittener Straße 82
44789 Bochum
Tel.: 0234-33 51 80
Fax: 0234- 30 82 17
info@paulgothe.de
www.paulgothe.de

Drawing-No.:
Gasentnahmesonde / gas sample probe

Be/Rd



Nachdruck und Vervielfältigung nur mit Genehmigung der Paul Gothe GmbH gestattet.
Zeichnung und Prinzip ist Eigentum der Paul Gothe GmbH

Duplication and reproduction only with permission of Paul Gothe GmbH.
Drawing and schematic diagram is the property of Paul Gothe GmbH

© Paul Gothe GmbH

Manual for the Gas Sampling Probe:

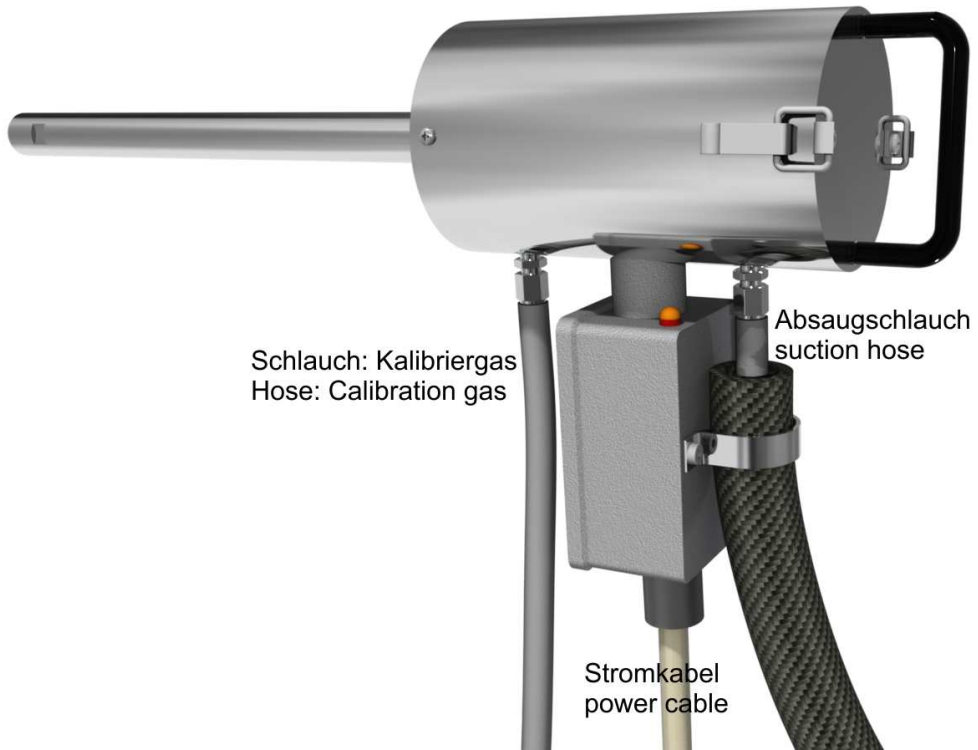
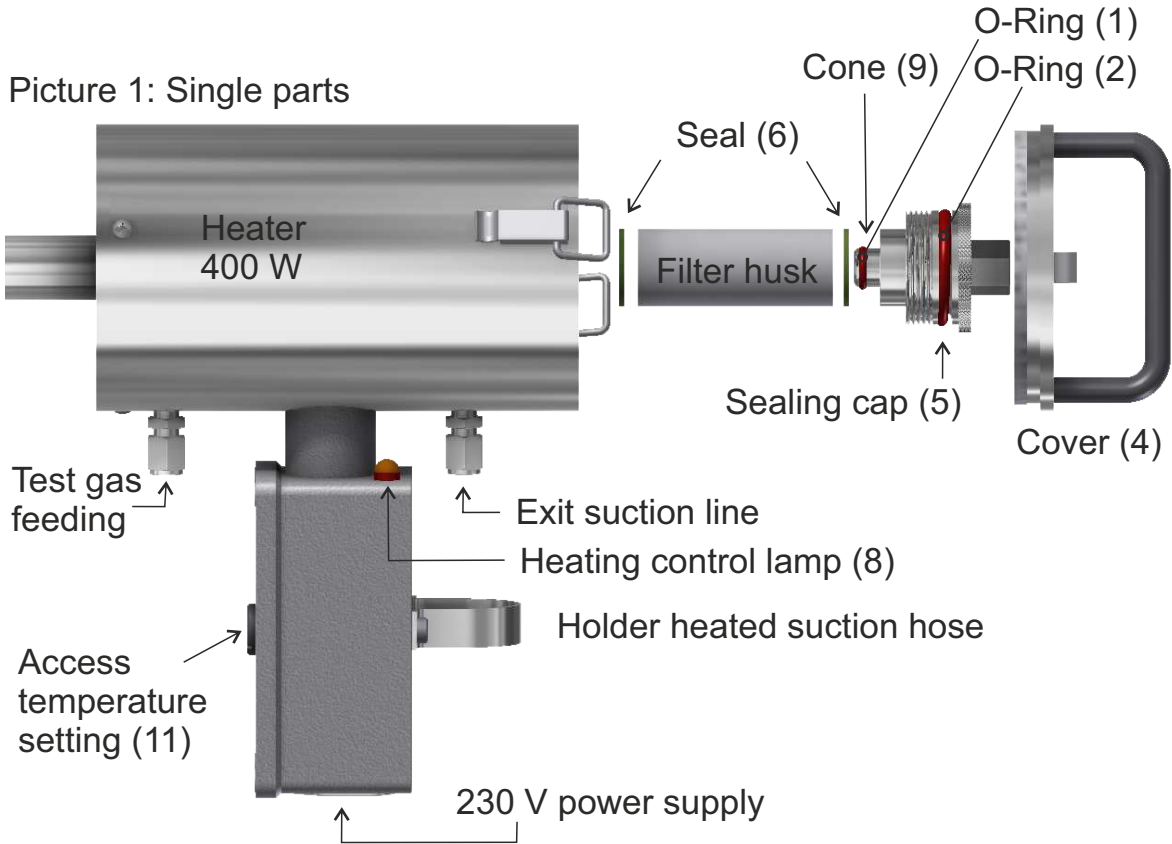

Paul Gothe GmbH
 Wittener Straße 82
 44789 Bochum
 Tel.: 0234-33 51 80
 Fax: 0234- 30 82 17
 info@paulgothe.de
 www.paulgothe.de

Zeichnungs-Nr.:

Gasentnahmesonde / gas sample probe -2

Be/Rd

Nachdruck und Vervielfältigung nur mit Genehmigung der Paul Gothe GmbH gestattet.
 Zeichnung und Prinzip ist Eigentum der Paul Gothe GmbH

Duplication and reproduction only with permission of Paul Gothe GmbH.
 Drawing and schematic diagram is the property of Paul Gothe GmbH

© Paul Gothe GmbH

